

SCREW PUMP CATALOGUE



[Agronema.com](https://www.agronema.com)



E-mail:

info@agronea.com
sales@agronea.com

Tel: +49 06048 9529830 Deutsch/English
Mobile: +49 162 9158001 Deutsch only



https://www.youtube.com/channel/UCe9vRIjWGV5Fj_vLx_ihOZQ

VP SERIES SCREW PUMPS

VP series pumps provide high pressure (up to 100 bar) at low volumetric delivery (up to 50lt/min).

VP Screw pumps are mostly used on deep hole drilling applications on CNC machine tools. On deep hole drilling applications, while work-piece are drilled by cutting tool, coolant liquid are sprayed to the work-piece through the cutting tool. So work-piece and cutting tool can be cooled and metal chips can be thrown out enhancing the quality of machining. It also accelerates the process and prolongs the lifetime of cutting tool. Only high pressure pumps can overcome the high flow resistance of the system and provide required flow rate.

The medium is compressed by a set of spindles in VP series self-priming pumps. Rotation of the driving (main) screw provides the pumped medium to move continuously from suction to the discharge port. The special profile formation of the spindles leads to a minimum leakage between the spindles and provides a high level of efficiency. VP series screw pumps have a pressure control and a regulation valve that is required for the safety of the system.

VP series features:

- High efficiency,
- High reliability,
- Low noise level,
- Self-priming capacity,
- Near-zero pulsation.

Primary application areas of VP series screw pumps:

- a. Machine tools and machining centres,
 - Pumping of the coolant and lubricant fluid (minimum 5% oil)
 - Deep hole drilling applications for cooling machine tool and work-piece and to remove the chips out of the hole.
- b. Hydraulic systems,
 - Pumping for coolants and fluids with high viscosity (between 1-400 cSt)
- c. Central units for heat exchange and energy recover,
 - Circulation of the system fluid
- d. Due to its wear-resistant design
 - Processes that difficult to mill materials such as titanium and stainless steel,
 - High precision applications such as aerospace industry,
 - Grinding applications.

Properties of the medium Fluids with lubricating properties such as

- Oil in water emulsions with minimum 5% oil.
- Cooling and cutting oils are suggested. Also, pumped fluid should not include abrasives or long fibre components. Installation of a strainer on the suction port of the pump has to be avoided. Usage of strainer creates additional forces on the suction port of the pump and as a result power consumption of the motor increases.

- Generally acceptable contamination:
 - Maximum solids contents: 120mg/l
 - Maximum grain size: 0.05mm (50µm) for machining (turning, milling, drilling) Special values can be applied on request. Recommended filtration quality and max. solid content of pumped fluid is given at page 4.
- Kinematic viscosity: 1-400 mm²/s (cSt)
- Operation temperature: 0 °C to 80 °C

VP type screw pumps are self-priming pumps with 4m geodesic suction head. Running dry and operation with closed valve is not permissible.

VP series screw pumps are delivered with tank lid, valve block and manometer shown in Figure 1.

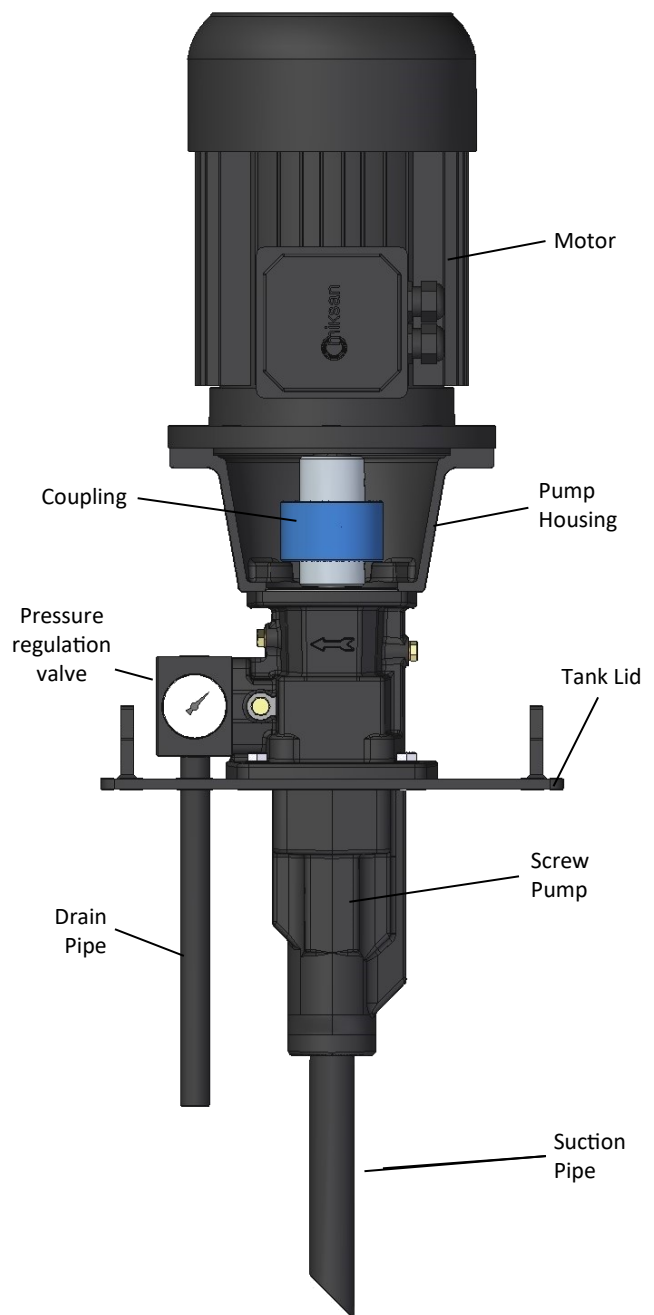
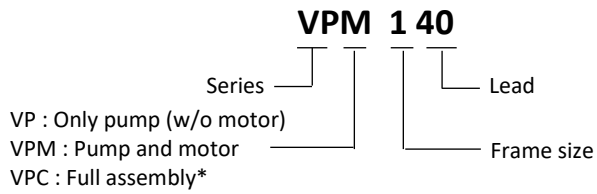

Figure 1. Configuration of VP series screw pump

VP screw pumps are offered in various pumps within a single frame size, combination with various motors is possible. Identification of the pump is given in Figure 2.



* Full assembly includes motor, screw pump, pressure regulation valve, pressure gauge, tank lid, suction and drain valve

Figure 2. Identification of VP series screw pumps

Performance curves of the VP series screw pumps at 2900RPM and viscosity of 1 cSt and 20 cSt are given in Figure 3. Please contact us for higher volumetric deliveries.

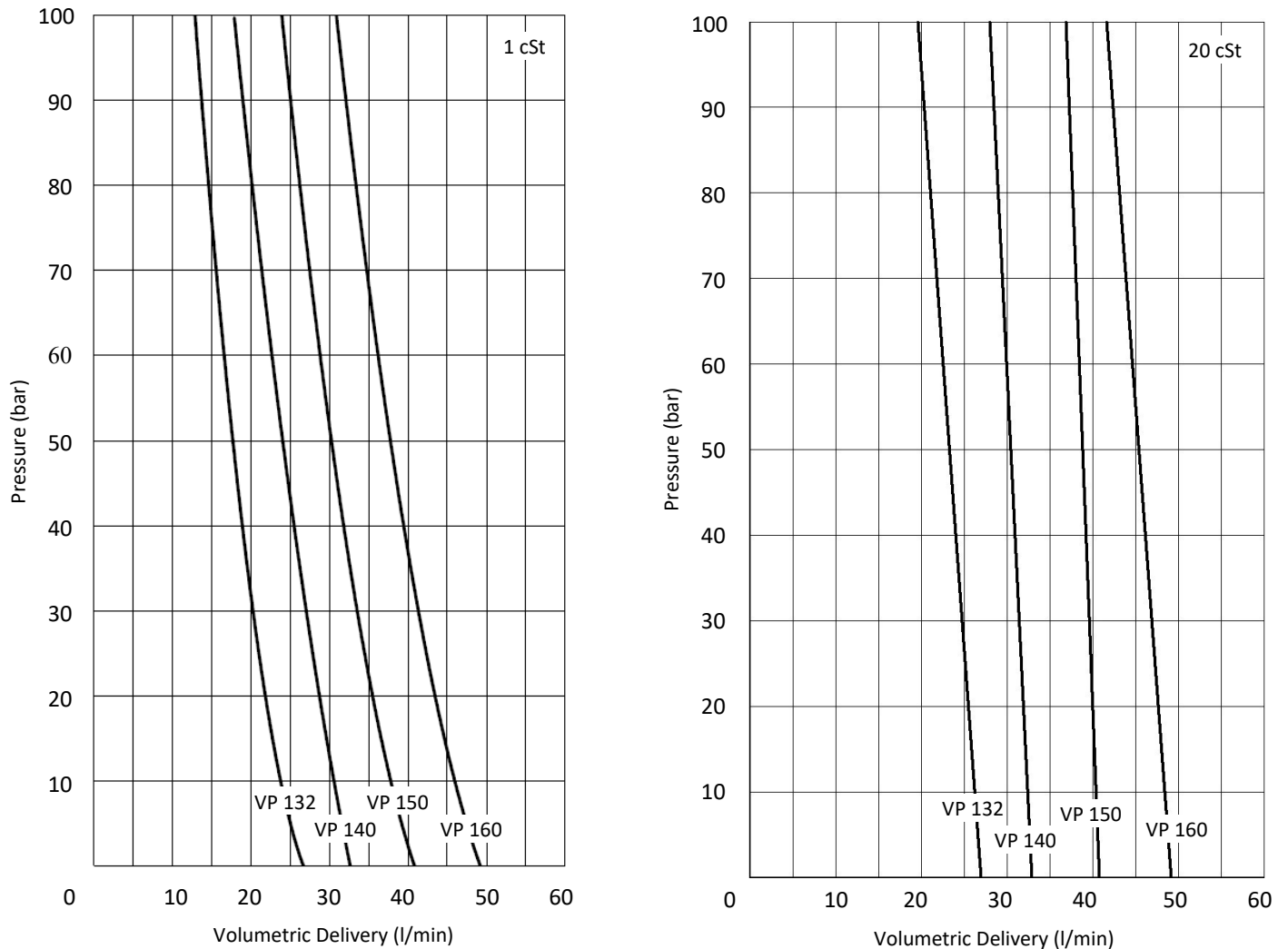
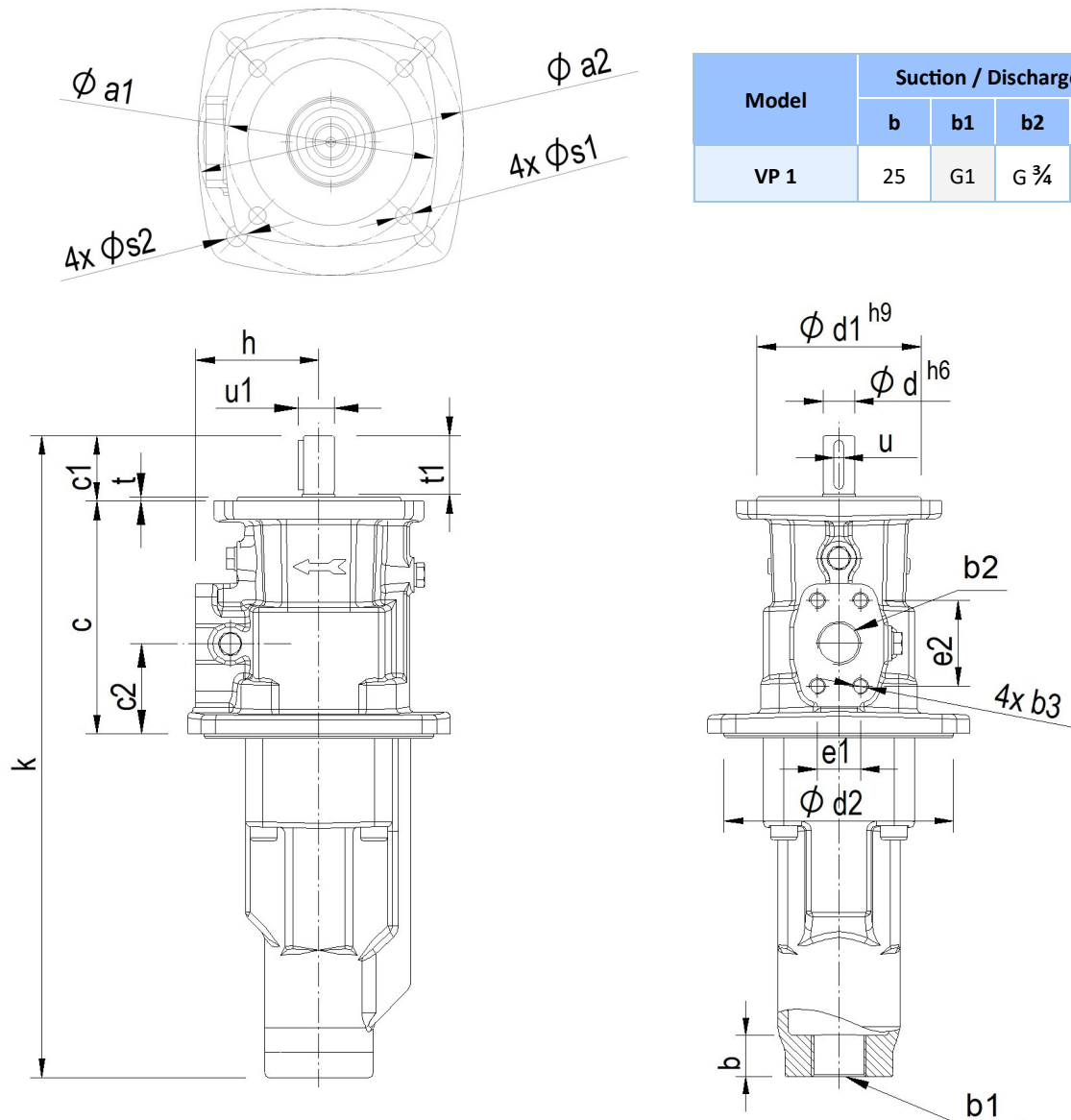

Figure 3. Performance curve of VP series screw pumps

Dimensions



Model	Suction / Discharge Dimensions (mm)					
	b	b1	b2	b3	e1	e2
VP 1	25	G1	G 3/4	M10	26,2	52,4

Model	Pump Dimensions (mm)															
	a1	a2	c	c1	c2	d	d1	d2	h	k	s1	s2	t	t1	u	u1
VP 1	125	160	142	40	55	19	100	140	75	392	10,5	12,5	2,5	36	6	21,5

Technical Parameters

Flow Rate	15 to 50 l/min
Liquid Temperature	Up to 80 °C
Inlet Pressure	Up to 10 bar
Max. Outlet Pressure	100 bar
Viscosity Range (v)	1 to 400 cSt (min 5% oil)
Dirt Load Level	Up to 120 mg/l
Filter Fineness	Up to 50 μ m

Recommended filtration quality of VP screw pumps

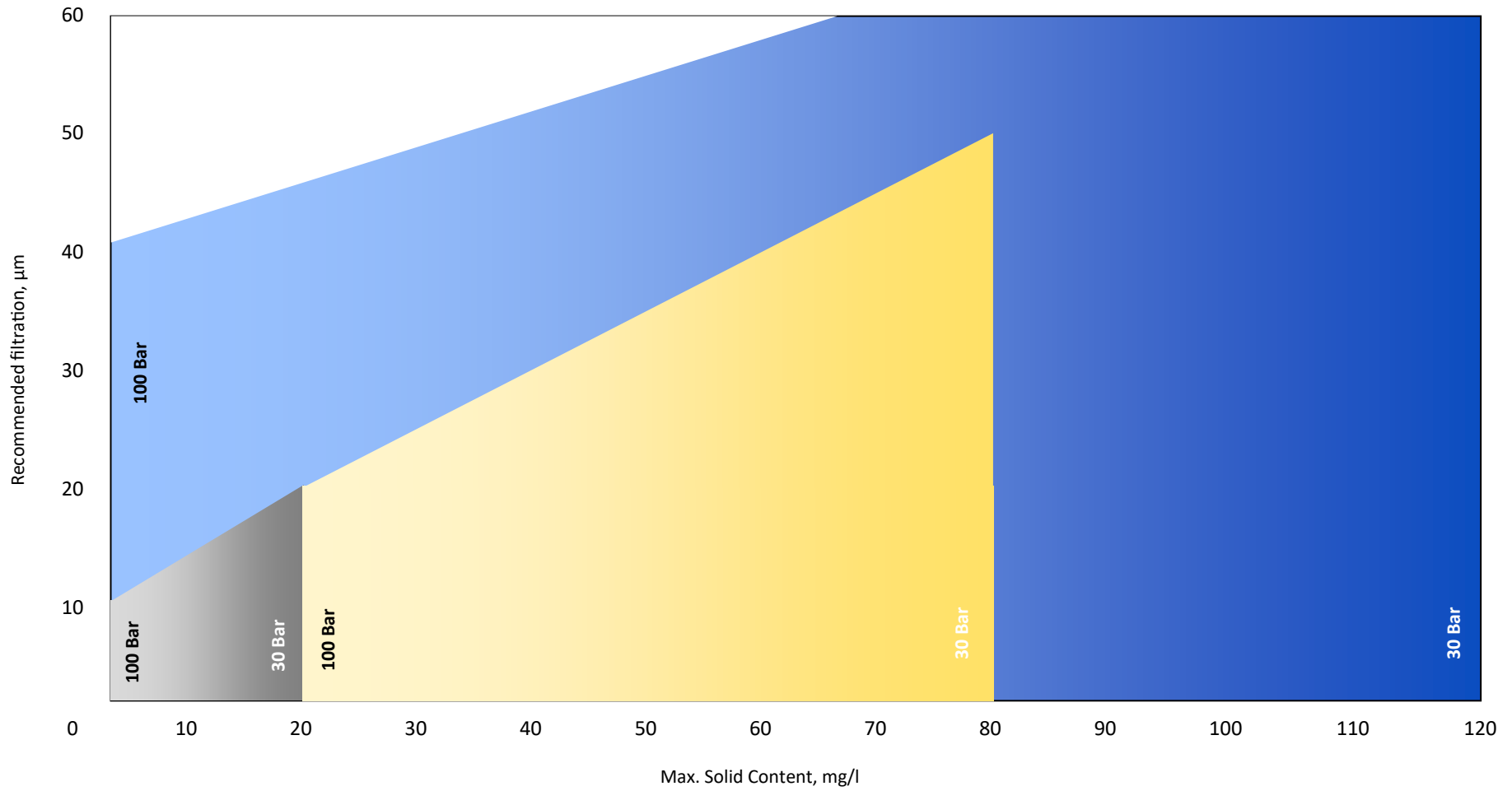

↑
1.000>10.000 HV
Very high hardness
(titanium, CBN)

↑
50>70 HRC
High hardness
(Hardened steel)

↑
<50 HRC
Average hardness
(Steel, GG, Al)

1 Screws

Special alloy steel, hardened 62 HRC, highly wear-resistant spindles extend the pump's service life,

3 Seal flushing

Back-flow from seal zone to pump inlet via safety valve when pressure exceeds 0.5 Bar

5 Sealing

maintenance-free SiC mechanical seal and Viton O-rings

2 Housing

Special heat treatment of pump housing to minimize friction and wear

4 Balancing piston

Ensures proper cooling and lubrication of mechanical seal surfaces and minimizes flow losses for higher efficiency

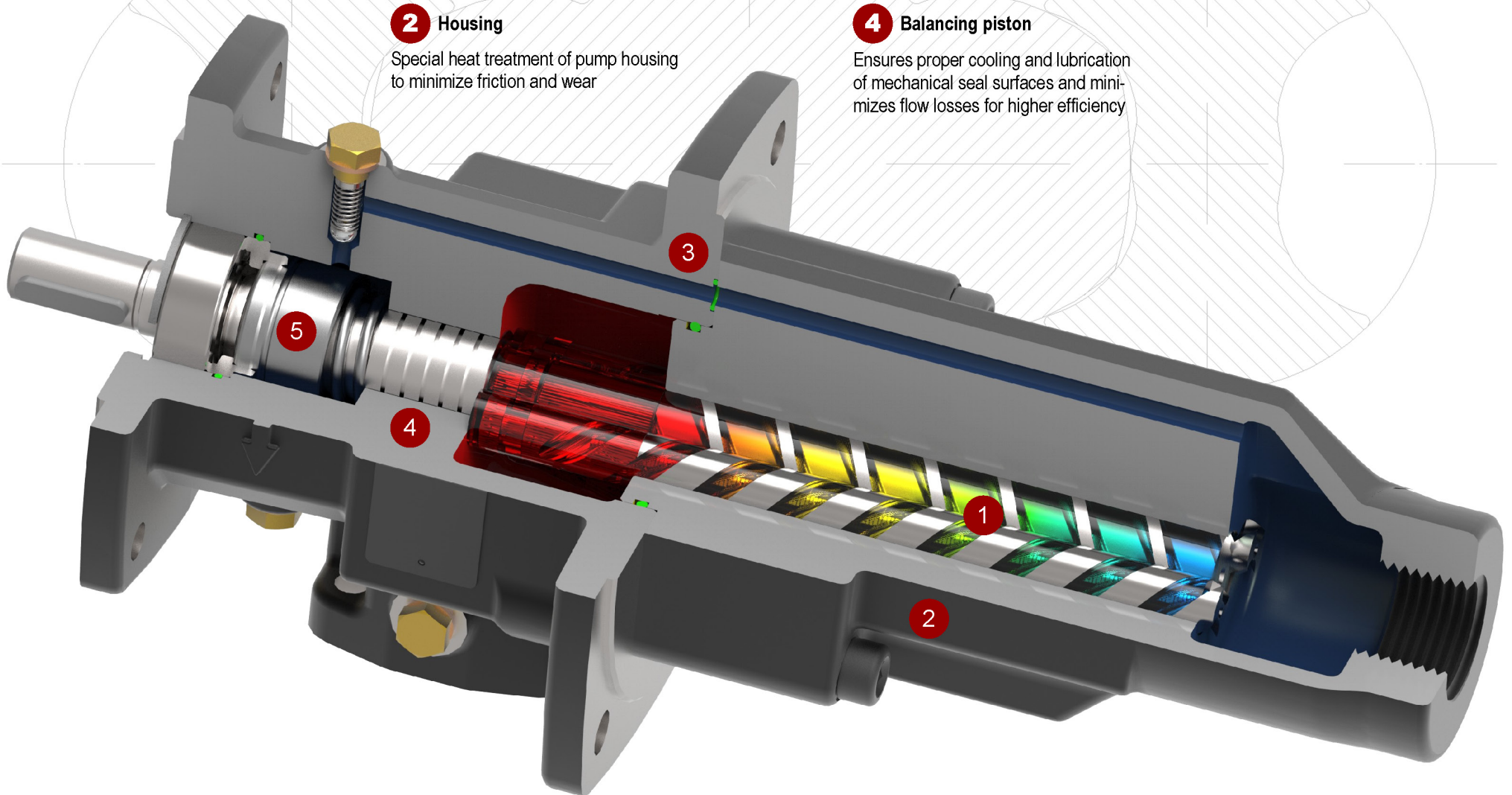



VP 132 SCREW PUMP

Applications:

- High pressure pumps with low volumetric delivery,
- Cutting, turning milling, boring, grinding and similar applications of the machine tools,
- Especially used for deep hole boring operations due to the high pressure up to 100 bar,
- Pumping cutting/cooling fluids in circulation systems,

Fluid Specifications:

- Coolants,
- Cutting oils,
- Grinding oils,
- Emulsions (minimum 5% oil),
- Thermal oils (contact for detailed information)
- Kinematic viscosity 1...400 mm²/s (contact for higher viscosities)

Materials:

Spindles	: High performance steel, hardened steel
Pump body	: Cast iron - DIN GG 26, specially heat treated
Discharge casing	: Cast iron - DIN GG 26
Housing	: Aluminium
Mechanical seal	: SiC-SiC-Viton
O-ring	: Viton
Suction pipe	: Steel
Motor	: 3-phase IE3 induction motor 2-pole, 2900 RPM; 4-pole, 1450 RPM (Optional) Protection degree, IP 55 Insulation class F

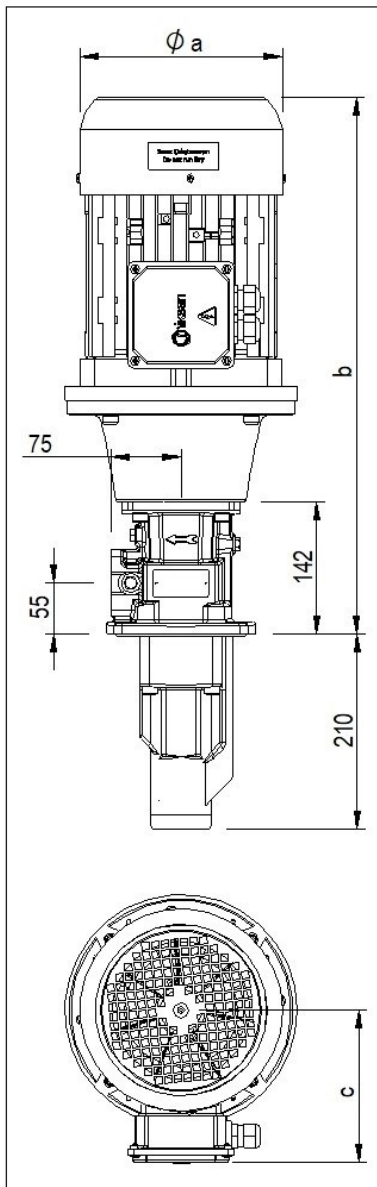

NOMINAL SIZE

Motor		Dimensions			Cable Gland
2 Pole	4 Pole	a	b	c	
kW		mm			
1,1	0,55/0,75	157	485	105	M16x1,5
1,5	1,1	176	495	124	M20x1,5
2,2	1,5	176	520	124	M20x1,5
3	2,2/3	194	560	145	M20x1,5
4	4	194	560	145	M20x1,5
5,5	-	218	580	157	M20x1,5

Pump Performance and Electrical Values

Type $Q_{TH}=26,7$ l/min	50 Hz	2900 RPM				Weight kg
	Max. Pressure bar	Flow Rate l/min		Motor kW		
		1 cSt	20 cSt	1 cSt	20 cSt	
VP 132	10	23,8	26,3	1,1	1,1	32
	20	22,2	25,4	1,5	1,5	36
	30	20,9	24,3	2,2	2,2	37.5
	40	19,5	23,5	2,2	2,2	37.5
	50	18,2	22,6	3	3	43.5
	60	17,1	21,8	3	3	43.5
	70	15,9	21,2	4	4	46.5
	80	14,6	20,4	4	4	46.5
	90	13,8	20,1	5,5	5,5	53
	100	12,9	19,6	5,5	5,5	53

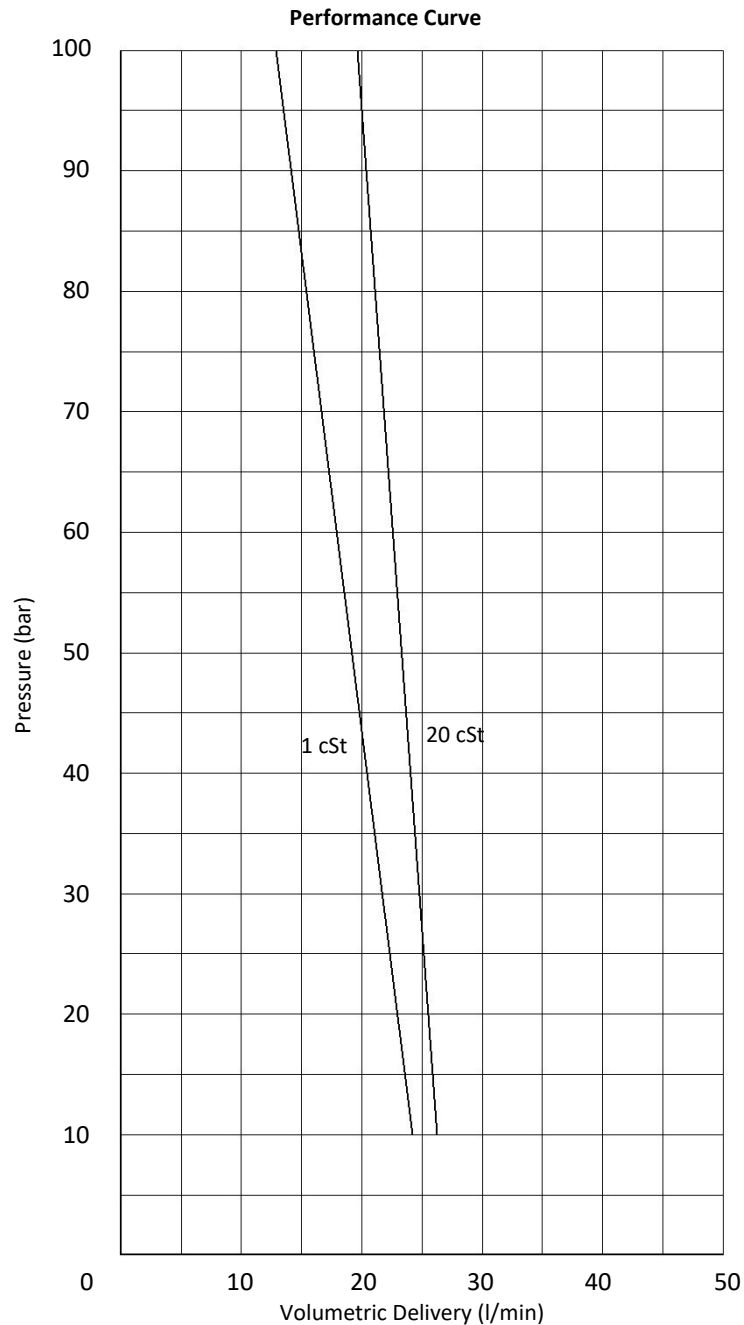

*Performance curves of the VP 132 series screw pumps at 2900 rpm and viscosity of 1 cSt and 20 cSt. VP 132 can also be operated at 1450 RPM.



VP 140 SCREW PUMP

Applications:

- High pressure pumps with low volumetric delivery,
- Cutting, turning milling, boring, grinding and similar applications of the machine tools,
- Especially used for deep hole boring operations due to the high pressure up to 100 bar,
- Pumping cutting/cooling fluids in circulation systems,

Fluid Specifications:

- Coolants,
- Cutting oils,
- Grinding oils,
- Emulsions (minimum 5% oil),
- Thermal oils (contact for detailed information)
- Kinematic viscosity 1...400 mm²/s (contact for higher viscosities)

Materials:

Spindles	: High performance steel, hardened steel
Pump body	: Cast iron - DIN GG 26, specially heat treated
Discharge casing	: Cast iron - DIN GG 26
Housing	: Aluminium
Mechanical seal	: SiC-SiC-Viton
O-ring	: Viton
Suction pipe	: Steel
Motor	: 3-phase IE3 induction motor 2-pole, 2900 RPM; 4-pole, 1450 RPM (Optional) Protection degree, IP 55 Insulation class F

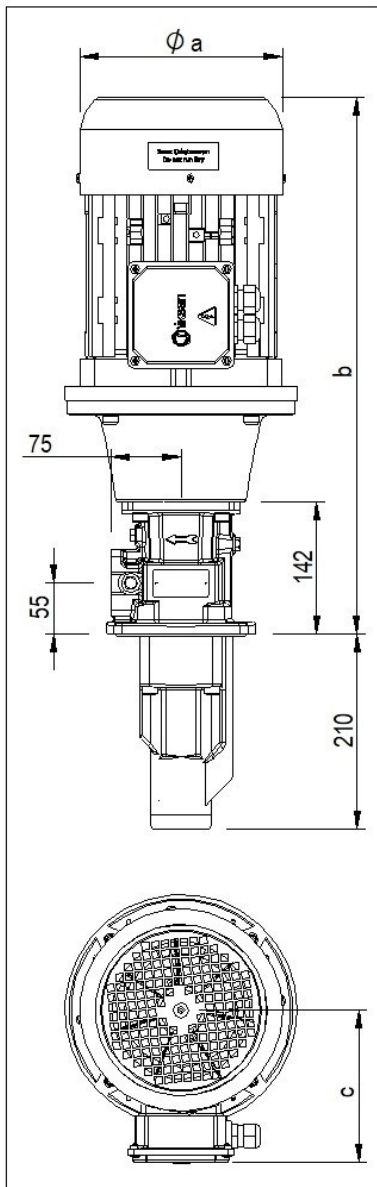

NOMINAL SIZE

Motor		Dimensions			Cable Entry
2-Pole	4-Pole	a	b	c	
kW		mm			
1,1	0,55	157	485	105	M16x1,5
-	1,1	176	495	124	M20x1,5
2,2	1,5	176	520	124	M20x1,5
3	2,2/3	194	560	145	M20x1,5
4	4	194	580	145	M20x1,5
5,5	-	218	630	157	M20x1,5
7,5	-	258	705	198	M25x1,5

Pump Performance and Electrical Values

Type $Q_{TH}=32,7$ l/min	50 Hz	2900 RPM				Weight kg
	Max. Pressure bar	Flow Rate l/min		Motor kW		
		1 cSt	20 cSt	1 cSt	20 cSt	
VP 140	10	30,4	32,4	1,1	1,1	32,0
	20	28,7	31,8	2,2	2,2	37,5
	30	26,9	31,2	2,2	2,2	37,5
	40	25,8	30,6	3,0	3,0	43,5
	50	23,9	30,3	4,0	4,0	46,5
	60	22,9	30	4,0	4,0	46,5
	70	21,5	29,5	5,5	5,5	53,0
	80	20,1	29	5,5	5,5	53,0
	90	18,9	28,6	7,5	7,5	74,0
	100	17,9	28,2	7,5	7,5	74,0

Performance Curve

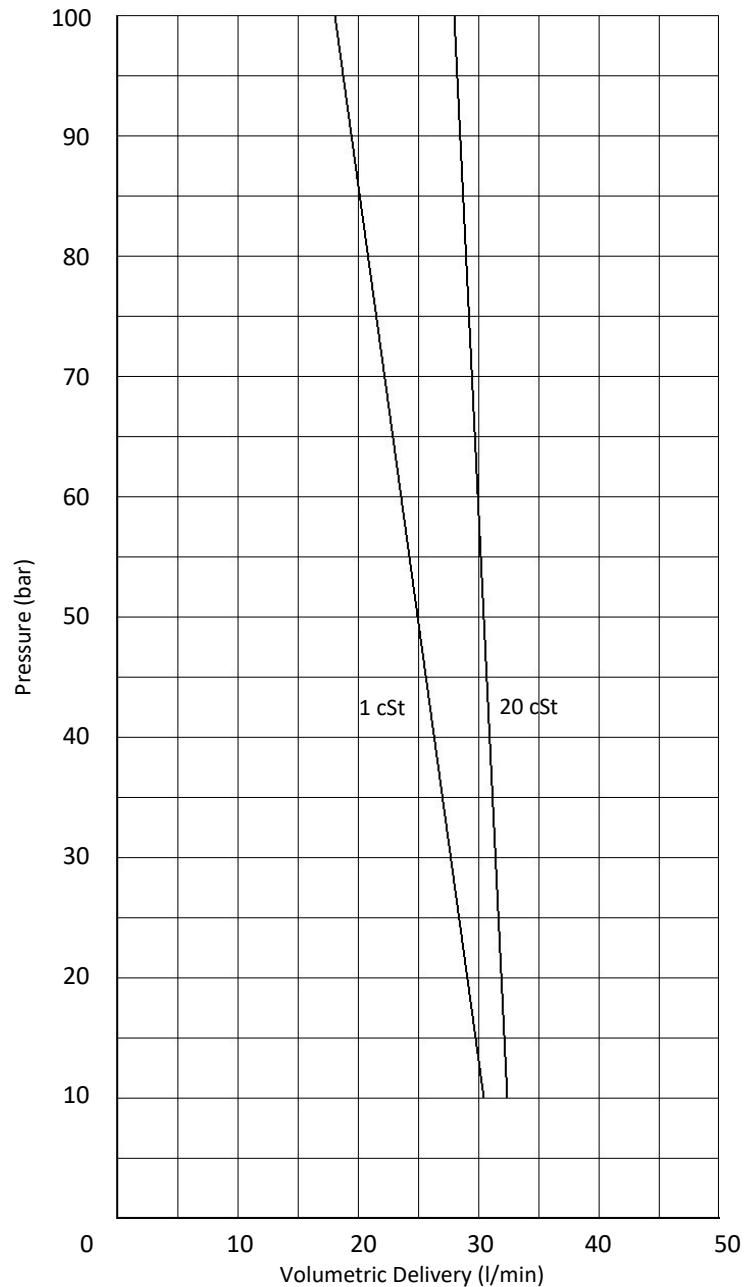

*Performance curves of the VP 140 series screw pumps at 2900 rpm and viscosity of 1 cSt and 20 cSt. VP 140 can also be operated at 1450 RPM.



VP 150 SCREW PUMP

Applications:

- High pressure pumps with low volumetric delivery,
- Cutting, turning milling, boring, grinding and similar applications of the machine tools,
- Especially used for deep hole boring operations due to the high pressure up to 100 bar,
- Pumping cutting/cooling fluids in circulation systems,

Fluid Specifications:

- Coolants,
- Cutting oils,
- Grinding oils,
- Emulsions (minimum 5% oil),
- Thermal oils (contact for detailed information)
- Kinematic viscosity 1...400 mm²/s (contact for higher viscosities)

Materials:

Spindles	: High performance steel, hardened steel
Pump body	: Cast iron - DIN GG 26, specially heat treated
Discharge casing	: Cast iron - DIN GG 26
Housing	: Aluminium
Mechanical seal	: SiC-SiC-Viton
O-ring	: Viton
Suction pipe	: Steel
Motor	: 3-phase IE3 induction motor 2-pole, 2900 RPM; 4-pole, 1450 RPM (Optional) Protection degree, IP 55 Insulation class F

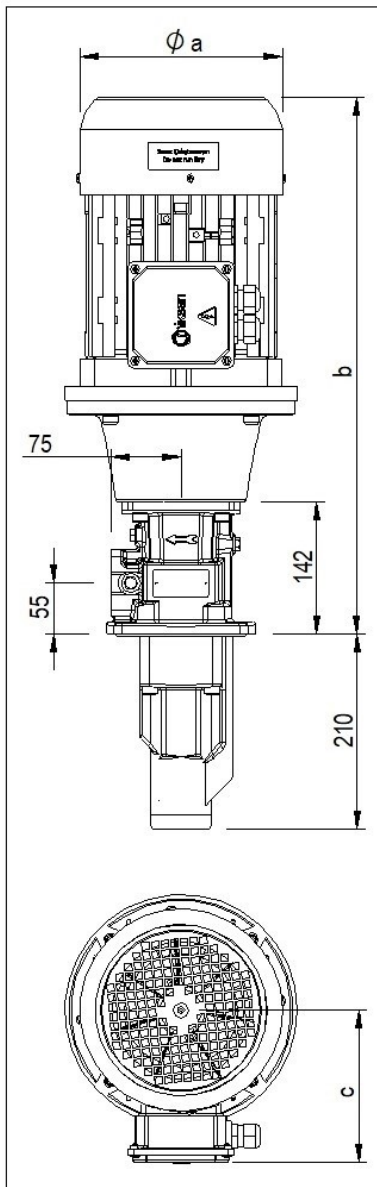

NOMINAL SIZE

Motor		Dimensions			Cable Entry
2-Pole	4-Pole	a	b	c	
kW		mm			
1,5	1,1	176	495	124	M20x1,5
2,2	1,5	176	520	124	M20x1,5
3	2,2	194	560	145	M20x1,5
4	3	194	580	145	M20x1,5
5,5	4	218	630	157	M20x1,5
7,5	5,5	258	705	198	M25x1,5

Pump Performance and Electrical Values

Type Q _{TH} =41,3 l/min	50 Hz	2900 RPM				Weight kg
	Max. Pressure bar	Flow Rate l/min		Motor kW		
		1 cSt	20 cSt	1 cSt	20 cSt	
VP 150	10	37,6	40,5	1,5	1,5	36,0
	20	35,4	39,6	2,2	2,2	37,5
	30	33,5	38,8	3	3	43,5
	40	31,8	38,3	4	4	46,5
	50	30,2	38	4	4	46,5
	60	28,9	37,7	5,5	5,5	53,0
	70	27,8	37,5	5,5	5,5	53,0
	80	26,2	37,2	7,5	7,5	74,0
	90	25	37	7,5	7,5	74,0
	100	23,9	36,7	7,5	7,5	74,0

Performance Curve

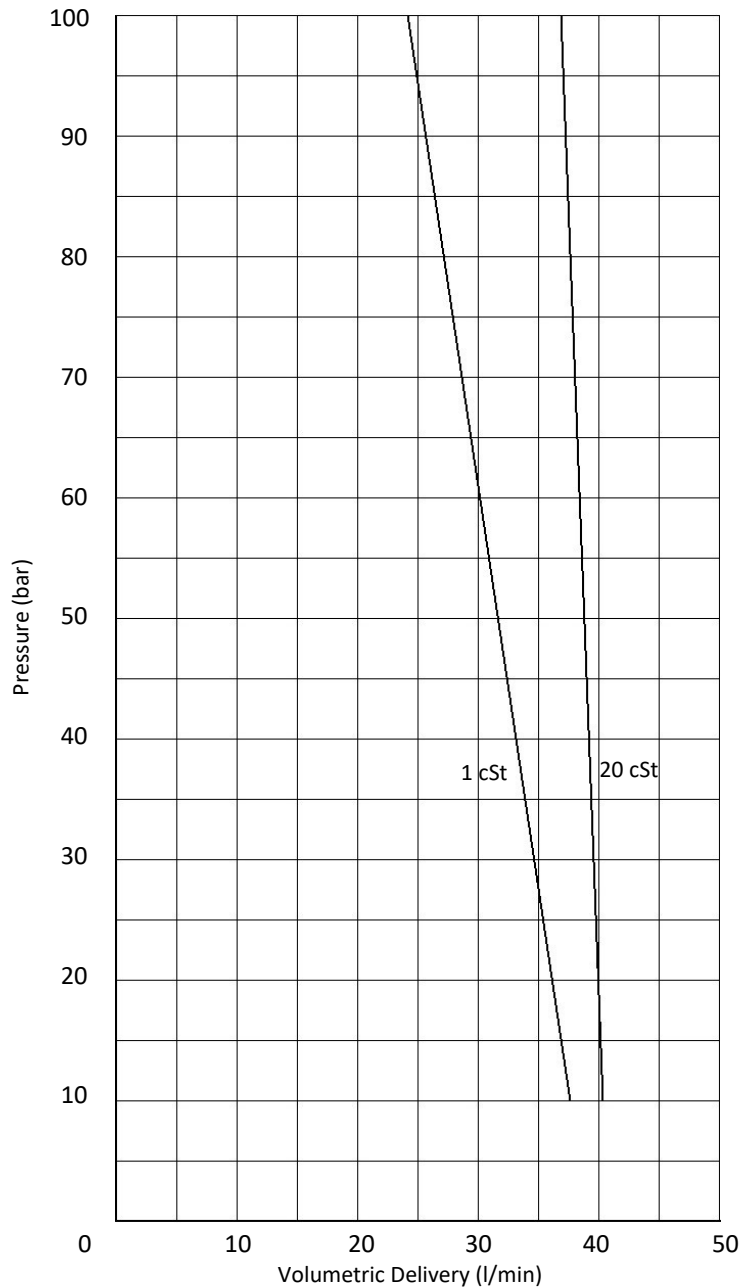

*Performance curves of the VP 150 series screw pumps at 2900 rpm and viscosity of 1 cSt and 20 cSt. VP 150 can also be operated at 1450 RPM.



VP 160 SCREW PUMP

Applications:

- High pressure pumps with low volumetric delivery,
- Cutting, turning milling, boring, grinding and similar applications of the machine tools,
- Especially used for deep hole boring operations due to the high pressure up to 100 bar,
- Pumping cutting/cooling fluids in circulation systems,

Fluid Specifications:

- Coolants,
- Cutting oils,
- Grinding oils,
- Emulsions (minimum 5% oil),
- Thermal oils (contact for detailed information)
- Kinematic viscosity 1...400 mm²/s (contact for higher viscosities)

Materials:

Spindles	: High performance steel, hardened steel
Pump body	: Cast iron - DIN GG 26, specially heat treated
Discharge casing	: Cast iron - DIN GG 26
Housing	: Aluminium
Mechanical seal	: SiC-SiC-Viton
O-ring	: Viton
Suction pipe	: Steel
Motor	: 3-phase IE3 induction motor 2-pole, 2900 RPM; 4-pole, 1450 RPM (Optional) Protection degree, IP 55 Insulation class F

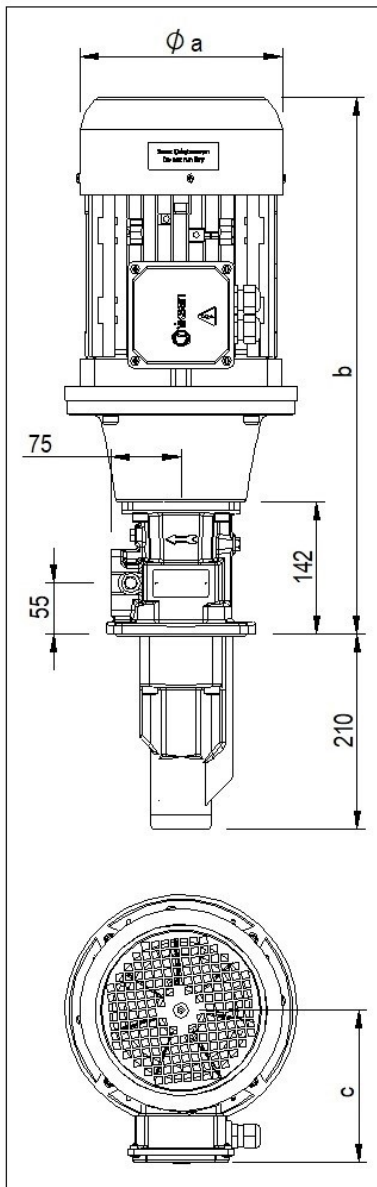

NOMINAL SIZE

Motor		Dimensions			Cable Entry
2-Pole	4-Pole	a	b	c	
kW		mm			
1,5	1,1	176	495	124	M20x1,5
2,2	-	176	520	124	M20x1,5
3	2,2	194	560	145	M20x1,5
4	3	218	580	157	M20x1,5
5,5	4	258	630	198	M20x1,5
7,5	5,5	258	705	198	M25x1,5
11	-	258	705	198	M25x1,5

Pump Performance and Electrical Values

Type $Q_{TH}=49,2$ l/min	50 Hz	2900 RPM				Weight kg
	Max. Pressure bar	Flow Rate l/min		Motor kW		
		1 cSt	20 cSt	1 cSt	20 cSt	
VP 160	10	45,5	47,6	1,5	1,5	36,0
	20	43,9	44,5	2,2	2,2	37,5
	30	41,2	42,7	3	3	43,5
	40	39,6	41,6	4	4	46,5
	50	38,1	41	5,5	5,5	53,0
	60	36	40,5	5,5	5,5	53,0
	70	34,5	40,2	7,5	7,5	74,0
	80	33,4	39,8	7,5	7,5	74,0
	90	31,9	39,5	11	11	81,0
	100	31,3	39,2	11	11	81,0

Performance Curve

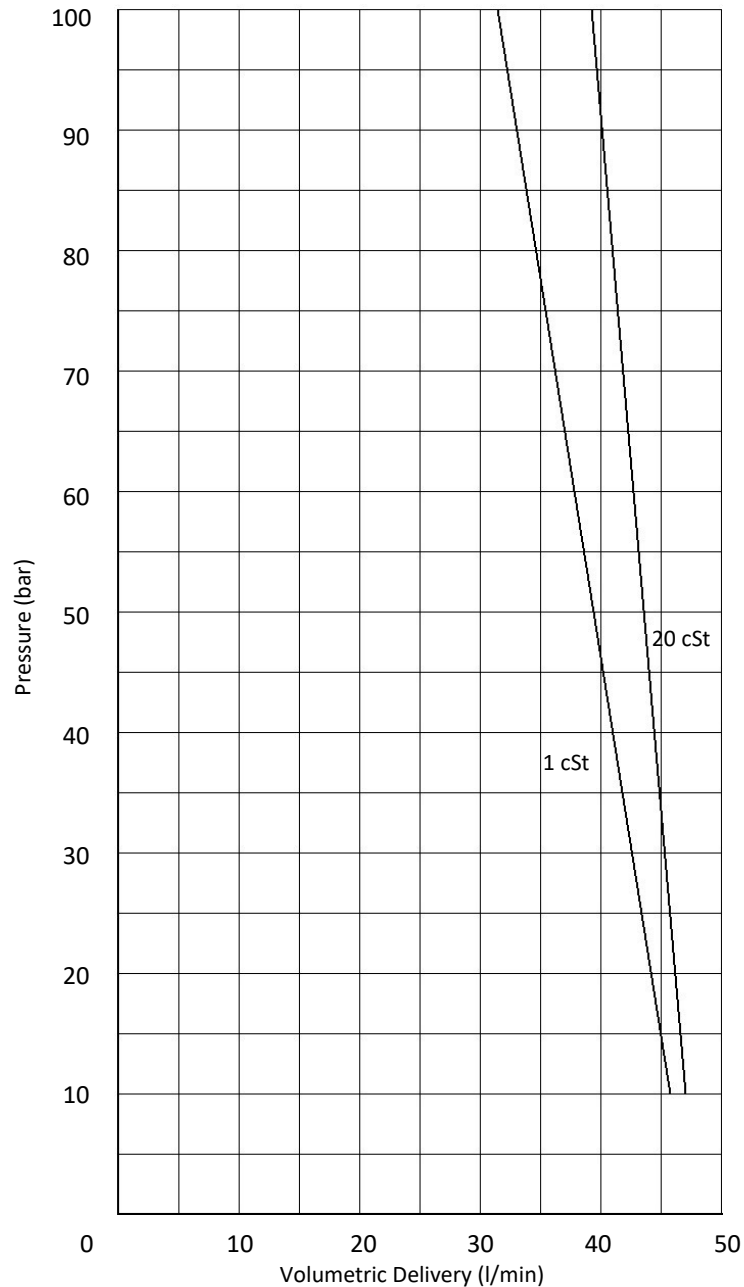

*Performance curves of the VP 160 series screw pumps at 2900 rpm and viscosity of 1 cSt and 20 cSt. VP 160 can also be operated at 1450 RPM.

ACCESSORIES

Adjustable pressure relief valve

Maximum pressure of screw pumps, which are displacement pumps, must be limited due to their design. Thus, the maximum working pressure have never exceed the highest allowable working pressure to avoid overloading for the particular pump and electrical motor combination in use and to protect the piping installation.

VPV series adjustable pressure relief valves allow for variable operating pressures anywhere between 10– 100 bar and allows the discharge back to tank.

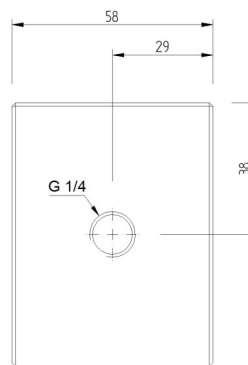
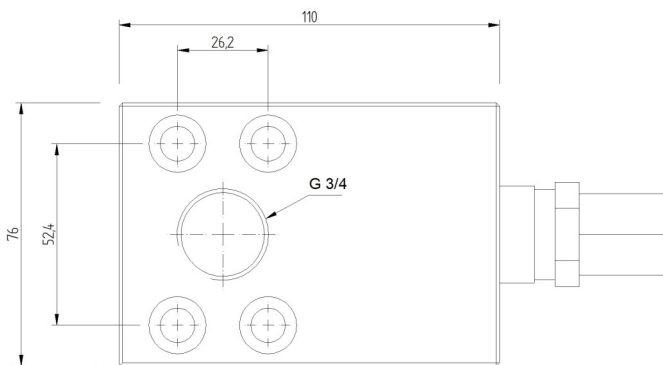

Type	Pump Model
VPV 01	VP 1

Full Assembly

Full assembly includes motor, screw pump, pressure regulation valve, pressure gauge, tank lid, suction and drain valve

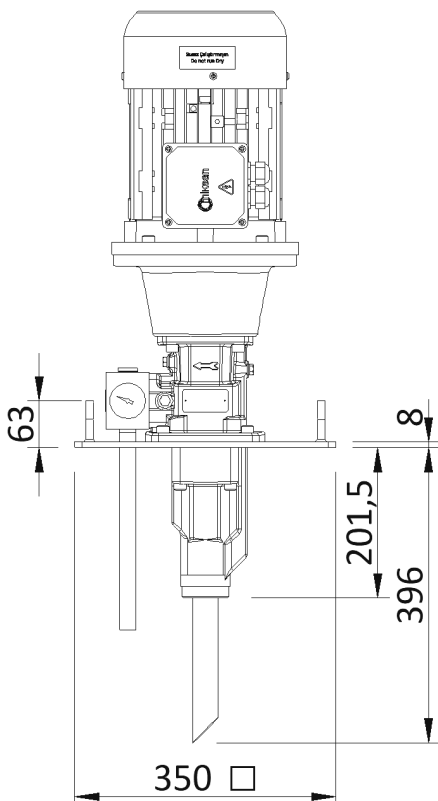

Installation accessories

The plate which the screw pump will be mounted and the connection pipes for complete system are provided upon request.

